

Fuzzy controller system utilization to increase the hydrogen production bioreactor capacity: toward sustainability and low carbon technology

Kairat A. Kuterbekov¹, Kenzhebatyr Zh. Bekmyrza^{1,*}, Asset M. Kabyshev¹, Marzhan M. Kubenova¹ and Mehrdad Shokatian-Beiragh^{2,*},[†]

¹Faculty of Physics and Technical Science, L.N. Gumilyov Eurasian National University, 010008, Satpayev st. 2, Astana 010008, Kazakhstan; ²Department of Water Resources Engineering, Faculty of Civil Engineering, University of Tabriz, Tabriz 5166616471, Iran

Abstract

The utilization of bio-hydrogen as a fuel source holds immense promise as a renewable energy option, offering compelling economic and environmental advantages. This study investigates the economic and environmental advantages of bio-hydrogen as a renewable energy source compared to fossil fuels, focusing on the reduction of greenhouse gas emissions such as carbon dioxide and carbon monoxide. The enhancement of anaerobic hydrogen production reactor capacity is explored through the application of a fuzzy controller system. Numerical simulations demonstrate that the fuzzy controller outperforms other methods in augmenting biological hydrogen production, effectively addressing the inherent non-linear characteristics of the system. In contrast, limitations in robustness against system uncertainty are observed with the non-linear controller. Exceptional tracking of desired values by the fuzzy controller, even in the presence of model uncertainty, results in a lower integral of time multiplied by squared error (ITSE) performance index compared to non-linear and proportional–integral controllers. Emphasizing the viability of the fuzzy method for regulating hydrogen production processes, potential gains of up to 95% in biological hydrogen production are indicated compared to open-loop configurations. This clean-burning fuel holds promise for industrial applications, contributing to the reduction of harmful gas emissions. The findings underscore the transformative potential of the fuzzy controller system in advancing sustainable hydrogen production and its significant role in addressing environmental concerns.

Keywords: bioreactor; bio-hydrogen production; fuzzy controller; low carbon; fuel

*Corresponding author:

kbekmyrza@yandex.kz;
m.shokatian.s@gmail.com

Received 6 November 2023; revised 22 January 2024; accepted 4 February 2024

1 INTRODUCTION

The growing demand for energy, combined with the depletion of conventional fossil fuel reserves, has compelled governments to investigate alternative sources of energy [1–5]. Renewable energies, including biological energies, can be evaluated using a variety of criteria, including their ability to ensure energy security, their potential for renewable and sustainable production and their ability to protect environmental health and reduce carbon emissions. Furthermore, these sources have the potential to replace fossil

fuels [6–10]. Bioenergy comes in a variety of forms, including bioethanol, biogas, biodiesel and bio hydrogen [11–13]. Biological hydrogen is defined as hydrogen produced through biological mechanisms and is widely recognized as a highly environmentally friendly energy source [14, 15]. Bio-hydrogen has a high energy density and produces only water vapor when combusted. As a result, it has fewer negative environmental consequences than conventional fuels [16, 17]. Many waste materials, such as solid and industrial waste, urban sewage sludge and waste from the livestock and poultry industries, have the potential to be

[†], <https://orcid.org/0000-0002-5849-7043>

International Journal of Low-Carbon Technologies 2024, 19, 667–675

© The Author(s) 2024. Published by Oxford University Press.

This is an Open Access article distributed under the terms of the Creative Commons Attribution License (<https://creativecommons.org/licenses/by/4.0/>), which permits unrestricted reuse, distribution, and reproduction in any medium, provided the original work is properly cited.

<https://doi.org/10.1093/ijlct/ctae026>

converted into biological hydrogen. This process may help to reduce a variety of environmental pollutants. The field of hydrogen production has received increased attention because of its potential as a fuel source [18, 19]. However, a number of issues and limitations preclude the use of hydrogen on an industrial scale.

Biological hydrogen is produced using a variety of processes and microorganisms [20]. While non-biological techniques such as water electrolysis, the use of fossil fuels with partial oxidation of hydrocarbons and the gasification process can be used to generate hydrogen, these methods have been shown to cause environmental pollution and greenhouse gas emissions [21]. Furthermore, they are not deemed economically feasible. Biological hydrogen production techniques include light utilization, anaerobic fermentation in both illuminated and dark conditions and the use of microbial electrolysis cells [22]. The efficacy of biophotolysis and photofermentation mechanisms is contingent upon the presence of light. The processes of direct and indirect photolysis yield hydrogen of higher purity compared to the processes of fermentation in the dark and fermentation in the light [23]. The biological hydrogen generated in the latter two processes comprises not only hydrogen and carbon dioxide but also other gases such as methane, carbon monoxide, hydrogen sulfide and ammonia, albeit in smaller quantities [24]. Additionally, there exist substances that necessitate elaborate purification procedures. Photo bioreactors are utilized for light-dependent processes, while fermentors are employed for dark-dependent fermentation processes [25].

The two main barriers to the commercialization of biological processes for hydrogen production are high production costs and low reaction yields [26]. The operating conditions have a significant impact on the response gain, which can be increased by adjusting the operating conditions so that they are closest to ideal. Substrate concentration is one of the most crucial operating conditions in the production of anaerobic biological hydrogen. It has been demonstrated through research that the concentration of the substrate significantly affects the rate of hydrogen synthesis [27]. Additionally, the concentration of the substrate in various biological processes slightly boosts their efficiency.

The manual regulation of bioreactor operating conditions is a laborious and expensive undertaking. Furthermore, the intricacies of bioreactors not only result in operational conditions that diverge from the optimal state, but also have the potential to induce system instability [28, 29]. Consequently, it is imperative to employ the suitable control strategy for the production of bio-hydrogen on a large scale. The efficacy of the product derived from a bioreactor is primarily contingent upon the utilization of a control loop mechanism to oversee and regulate the proliferation of microorganisms in accordance with the designated reference input. In addition, unforeseen external or internal disruptions within a reactor have the potential to lead to a breakdown of the reactor. Consequently, the control methodology is typically tailored to suit a particular bioreactor performance.

Using a model predictive control approach, Aceves-Lara et al. [30] proposed a closed-loop optimization of the bio-hydrogen production in continuous fermentation. The effectiveness of

digital control used for stabilizing the biochemical process in comparison to other Proportional–integral–derivative (PID) controllers was studied [31]. A high gain controller has been successfully used in the biological hydrogen production process [32]. The concentration of hydrogen in the gas phase of the liquid flow is measured in the aforementioned control system to regulate chemical oxygen demand (COD). López Pérez et al. [33] implemented a controller to regulate the dynamic behavior of a continuous bioreactor for biogenic hydrogen production. The closed-loop performance of the bioreactor resulted in a significant increase in hydrogen production.

This study contributes to the application of the fuzzy logic method to regulate substrate concentration, addressing the inherent non-linearity of the reactor system. This innovative approach distinguishes our work from conventional methods. To ascertain the effectiveness of our proposed controller, we conducted a numerical simulation by comparing its performance with that of a conventional proportional–integral (PI) controller and an advanced non-linear controller (NC). By highlighting the distinctive features of our fuzzy logic-based controller and its implications for increasing bioreactor capacity, this study significantly advances the field toward sustainable and low-carbon hydrogen technology.

2 MATERIALS AND METHODS

This section delves into the theoretical foundations and mathematical background of the research, encompassing the modeling of the biological system and the control system.

2.1 Bio-reactor model

The anaerobic fermentation process refers to the enzymatic breakdown of substrates by microorganisms in an oxygen-deprived environment, resulting in the alteration of molecular composition and the emergence of novel compounds. The aforementioned procedure is executed on an industrial scale within a biological reactor. Typically, in order to guarantee the appropriate quality of the reactor feed, the mixture of the reaction is formulated within a chamber that is equipped with a stirring mechanism. In instances where light is required for fermentation, sunlight is utilized, and in cases where insufficient light is available, LED panels are employed as a substitute [34]. Figure 1 depicts the schematic diagram of the fermentation process.

The production of bio-hydrogen fuel is dependent on the reaction method employed, which utilizes a diverse array of substrates and residues. The growth in population has led to a significant challenge for urban communities, namely the proliferation and accumulation of waste and residues. However, a potential solution to this issue is the conversion of these waste materials into hydrogen, which not only mitigates the accumulation of waste but also generates a valuable material. Moreover, a considerable number of these sources exhibit high potential as substrates for biological hydrogen production owing to their copious availability of nutrients, including lipids, minerals and vitamins [35]. Lignocellulosic

Mixing Starch and Rhodobacter Sphaeroides

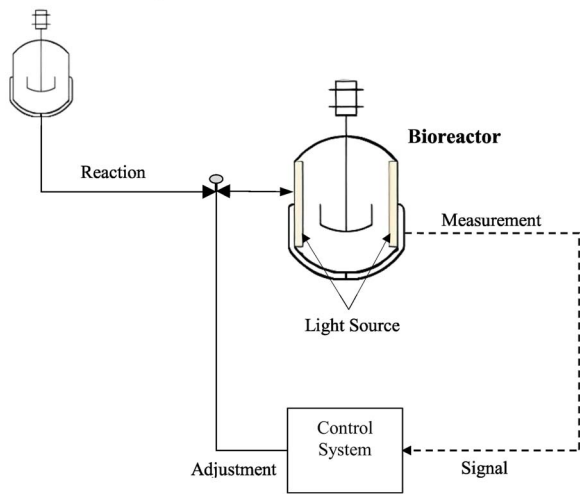

Figure 1. Bio-hydrogen production process with control system scheme.

biomass is considered one of the most easily accessible substrates for hydrogen production. This has led to a significant amount of attention being directed toward it, owing to its abundant nature, renewability and potential for hydrogen production [36]. Lignocellulosic sources, which are abundant in waste from forests, agriculture and animal manure, are highly enriched. The lignocellulosic masses are composed of three primary constituents, namely cellulose (40%), hemicellulose (25%) and lignin (20%), with the remaining (15%) being minute inorganic compounds [37]. Plant-based products such as flax and hemp are known to contain cellulose, a key component of plant cell structures. However, in order to utilize these components, it is necessary to undergo decomposition reactions to produce monomeric units. This can be achieved through various methods including physical (hydrothermolysis—steam pressure), chemical (acid and base) and biological means. The utilization of lignocellulosic substrates is a crucial aspect to consider, as the presence of lignin compounds has the potential to impede enzyme activity and subsequently reduce the efficacy of hydrogen production. Cellulose is a preferred substrate for hydrogen production in comparison to hemicellulose and lignin [36]. Starch, being a high molecular weight polymer, is unable to traverse the cell membrane in its polymerized form. As a result, it necessitates decomposition into its constituent units, which can be achieved through the utilization of enzymes and a variety of decomposition techniques, including physical, thermal, biological or a combination thereof. Starch-rich compounds, namely residues from potato factories, cow manure and sludge, have been identified [38]. The utilization of agricultural residues, encompassing plant commodities that are deemed unsuitable for commercialization across various markets, in conjunction with both simple and intricate carbohydrate polymers, serves as a substrate for the generation of hydrogen. Moreover, animal excreta and fertilizers harbor a plethora of microorganisms capable of producing hydrogen and are deemed valuable substrates owing to their renewable character and nutrient-rich

composition. Bioenergy can be generated and energy recovery can be achieved through the utilization of diverse domestic and industrial wastewaters [39]. Substrates required for hydrogen production can be obtained from various sources such as wine and beer factories, sugar processing and molasses, among others [35]. Simultaneous cultivation has been identified as a potential strategy for enhancing hydrogen production. *Rhodobacter sphaeroides*, a well-known non-sulfur purple bacteria, exhibits remarkable potential for hydrogen production under anaerobic conditions owing to its versatile substrate utilization and high enzymatic activity. The present study focuses on the examination of starch as the substrate of interest and *R. sphaeroides* as the microorganism under scrutiny.

Initially, the concoction of the substrate and microorganism is formulated within the blending vessel as part of the aforementioned procedure. Subsequently, the reaction mixture is consistently conveyed to the biological location. The reactor facilitates biological reactions by establishing optimal operating conditions, including the regulation of substrate concentration and light intensity. The reactor is outfitted with a stirrer, as it has been demonstrated that the homogeneity of the reaction mixture has a positive impact on the generation of hydrogen [40]. The effluent, which is abundant in hydrogen gas, is discharged from the reactor in a continuous manner. The control valve affixed to the feed stream regulates both the feed flow rate and the subsequent dilution rate. Manipulating the placement of the aforementioned control valve facilitates regulation of the substrate concentration within the reactor. Equations 1 to 4 are derived to obtain the controlled variable of mass balance for the purpose of process control. The system under consideration encompasses several state variables, namely substrate concentration (S), biomass concentration (K) and volume of hydrogen production (H_2).

$$\frac{dS}{dt} = D(S_{in} - S) - \frac{1}{Y_{xs}} \mu(S)X, \quad (1)$$

$$\frac{dX}{dt} = -DX + \mu(S)X, \quad (2)$$

where S_{in} is the inlet substrate mass concentration and D is the dilution rate, the concentration of the input substrate and the coefficient of biomass of the substrate. $\mu(S)$ is the cell growth rate obtained from Monod's equation. The reason for using Monod's equation to model cell growth is the greater compatibility of this model with laboratory data compared to Michaelis–Menten's model [41–43].

$$\mu(S) = \mu_{max} \frac{S}{K_S + S}, \quad (3)$$

The substrate saturation constant (K_S) represents the upper limit of the cell growth rate in Equation 3. The Luedeking–Piret equation (Equation 4) of the adjusted controller can be utilized to determine the quantity of hydrogen generated, albeit solely in the

Table 1. Bioreactor model parameter for hydrogen production

μ_{max}	K_s	S_{in}	Y_{xs}	γ	δ
0.4 h^{-1}	10 g L^{-1}	10 g L^{-1}	0.7 g g^{-1}	5	16 h^{-1}

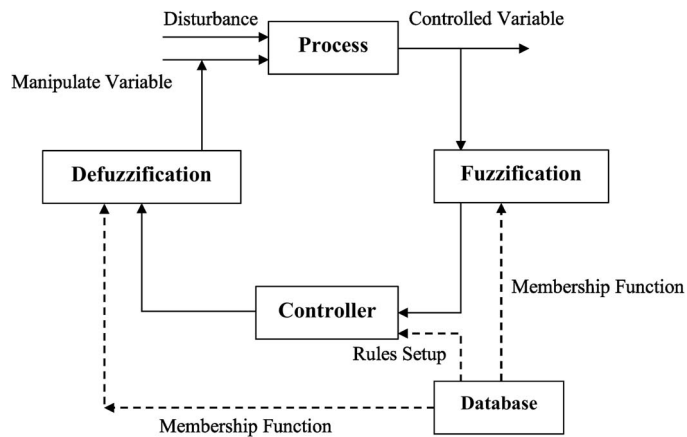

Figure 2. The structure of fuzzy control system.

vicinity of the intended operational threshold.

$$\frac{dH_2}{dt} = -DH_2 + \gamma \mu(S)X + \delta X, \tag{4}$$

where γ is constant. The values of the model parameters are summarized in Table 1.

2.2 Design of fuzzy controller system

The implementation of fuzzy control logic utilizing linguistic rules is reliant upon the expertise and past experiences of knowledgeable individuals. The diagram presented in Figure 2 depicts the configuration of fuzzy control logic.

The fuzzy controller is composed of three distinct components. The three constituent elements comprise fuzzification, fuzzy rule base and non-fuzzification [44]. The controller’s inputs consist of errors and changes in errors, which are mathematically defined by Equations 5 and 6.

$$e = S_R - S_m, \tag{5}$$

$$\dot{e} = \frac{de}{dt} = -\frac{dS_m}{dt}, \tag{6}$$

In the given equation, e represents the error, S_R denotes the reference concentration and S_m signifies the measured concentration. The process of fuzzification involves the utilization of five distinct membership functions for the error variable. The membership functions are depicted in Figure 3.

The fuzzification of the error derivative is carried out by utilizing three membership functions, as illustrated in Figure 4. The application of varying substrate concentrations to a fermentation

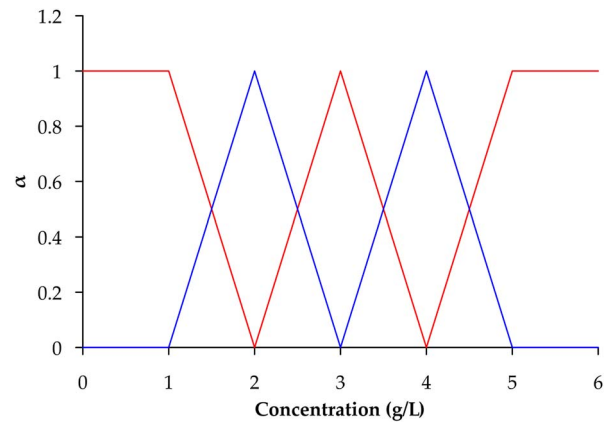

Figure 3. Fuzzification membership functions error.

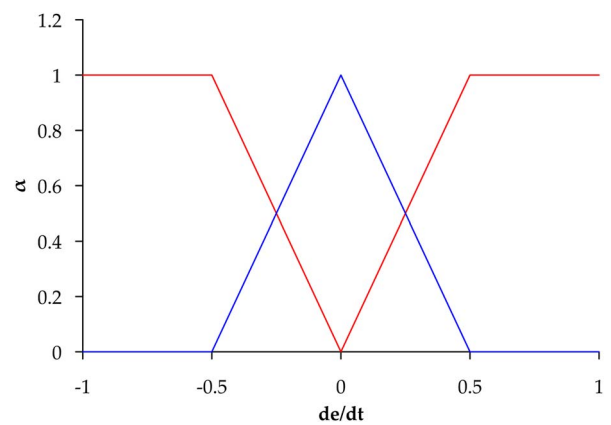

Figure 4. Fuzzification membership functions error derivation.

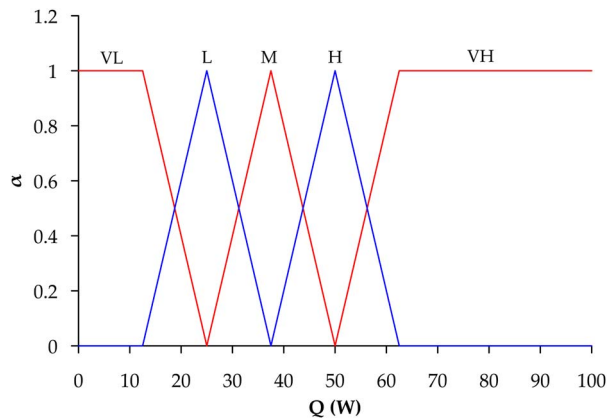

Figure 5. Fuzzy set membership functions.

system is denoted by VL, L, M, H and VH, which represent very low, low, medium, high and very high concentrations, respectively. The membership functions associated with the aforementioned fuzzy sets are depicted in Figure 5.

The utilization of the weighted average technique is employed for the purpose of de-fuzzification, with the aim of amalgamating

the inference derived from the fuzzy rules (Equation 7). Q_i output and α_i are expressed as a fuzzy set.

$$Q_{\text{fuzzy}} = \frac{\sum_{i=1}^n \alpha_i \times Q_i}{\sum_{i=1}^n \alpha_i}. \quad (7)$$

2.3 Numerical simulation

To evaluate the efficacy of the suggested controller, a closed-loop simulation was conducted on the bio-hydrogen production reactor that was outfitted with the controller. Figure 3 depicts the block diagram of a biological reactor for hydrogen production, which has been outfitted with a controller. The numerical solution of the differential-algebraic equations (DAE) in Python was utilized to simulate the process. The utilization of numerical differentiation formulas and the Adams–Bashforth–Moulton algorithm is employed in the resolution of DAEs. The algorithm that utilizes the variable step of variable order property is considered to be a highly appropriate solver for stiff systems and DAE. The present study examined the efficacy of the algorithm in terms of speed and accuracy through numerical simulation of the system under consideration. Comparative analysis with alternative algorithms revealed superior performance of the algorithm in question. The Adams–Bashforth–Moulton algorithm has been selected as the simulation algorithm due to this rationale.

3 RESULTS AND DISCUSSION

This section presents an analysis of the outcomes obtained from the simulation of the reactor under open-loop and closed-loop modes. Additionally, a comparative evaluation of the various controllers' efficacy has been conducted.

3.1 Validation of the model

A comparison has been made between the results of the modeled reactor's biological hydrogen production and the results of Sim et al. [45] in order to validate the current research model (Figure 6). The hydrogen production rate comparison results show that the current model closely matches the Sim et al. [45] model. This is determined by comparing the results. It is necessary to ensure that the root mean square error is equal to 3.21. As a result, the current research model can be utilized in a variety of settings and evaluated alongside other optimization strategies for conducting additional investigations.

3.2 Open-loop simulation of bioreactor without controller

Figure 7a depicts the Lag substrate's initial concentration at 4.9. During the startup phase, there is an initial increase in substrate concentration, followed by a decline before stabilizing around 0.85 g/L. This behavior is attributed to the influx of substrate initially surpassing efflux, resulting in limited biological activity.

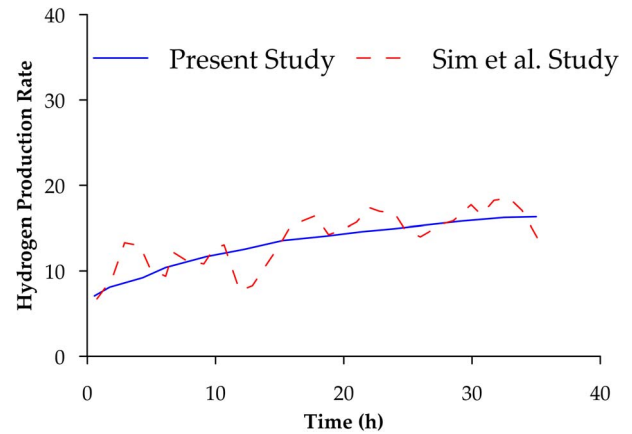

Figure 6. A comparison of the hydrogen production rate between the present study and Sim et al. [45] results.

Over time, as microorganisms proliferate and consume substrate, biological activity increases, leading to a decline in substrate concentration. Simultaneously, the initiation of microorganism activity triggers material decomposition, ultimately resulting in hydrogen generation (Figure 7b). The cumulative hydrogen production after 150 hours in the open-loop configuration reaches 3350 ml, highlighting the dynamics of substrate utilization and hydrogen generation in the absence of a controller. The nuanced interplay between substrate concentration, microbial activity and hydrogen generation underscores the complexities involved in optimizing bioreactor performance for enhanced hydrogen production.

3.3 Closed-loop simulation of bioreactor with controller

In the closed-loop mode, the system engages a controller to regulate substrate concentration to a predetermined value, displaying the impact of modifying the equilibrium point on hydrogen production augmentation. Figure 8 illustrates substrate concentration changes under closed-loop conditions. The controller activates at the 40-hour mark, coinciding with microbial activity onset and system equilibrium approach. After 40 hours, the controller regulates substrate concentration to reach the optimal level.

This study utilizes the PI controller for comparison with the fuzzy controller. The linearized controller adjusts parameters, encompassing those of the PI controller. Performance comparison involves the designed controller, PI controller and feedback NC [33]. Equation 8 represents the controlling relationship, providing a detailed exploration of the closed-loop system's dynamics and the efficacy of the PI controller in comparison to the designed controller. The results shed light on the effectiveness of the closed-loop control strategy in optimizing hydrogen production.

$$u = k_p e + k_I \int e dt. \quad (8)$$

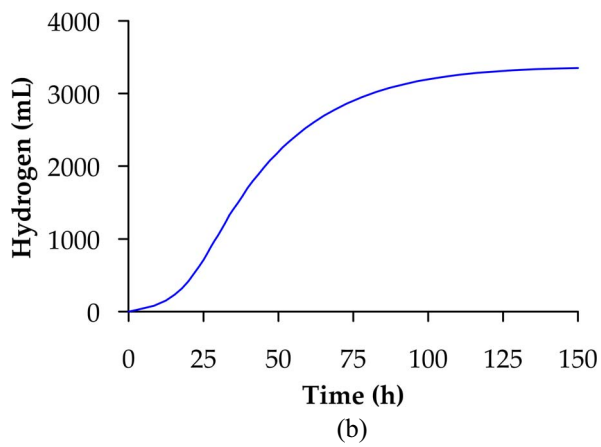
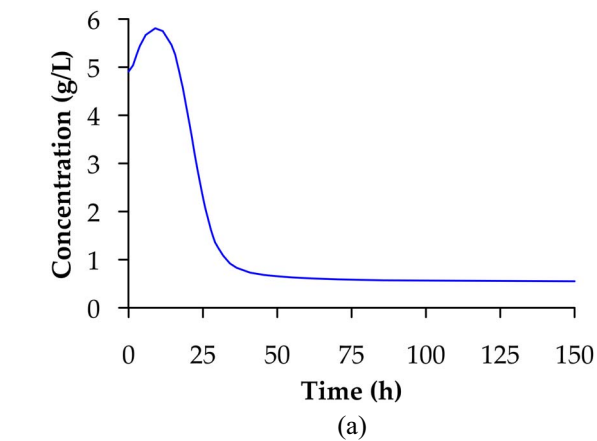

Figure 7. The amount of (a) substrate concentration and (b) hydrogen production in the open-loop system during the process.

The PI controller comprises two parameters, namely the proportional and integral parameters, denoted by k_p and k_I , respectively. Equation 9 represents the form of the relationship of the NC.

$$u = k_I (e^2 - k_2). \tag{9}$$

Equations 8 and 9 denote the control error by the variable e . Equation 9 has been selected as a NC on the grounds of ensuring its stability, which is established through the application of the Cauchy–Schwarz inequality. The exclusion of an integral term in this controller leads to a sustained error. To optimize controller performance, parameters, such as k_p and k_I , are configured. In the PI controller, specific values were assigned, with k_p set to 0.53 and k_I to 0.12. These parameter selections are crucial for achieving effective control and minimizing errors in the closed-loop system.

Figure 8b data highlights a notable rise in the hydrogen production rate under the closed-loop system, evident from the steeper curve slope. This emphasizes the pivotal role of process control in augmenting productivity. The data indicate that after 160 hours, the reactor generates 5545 ml of hydrogen, a 90%

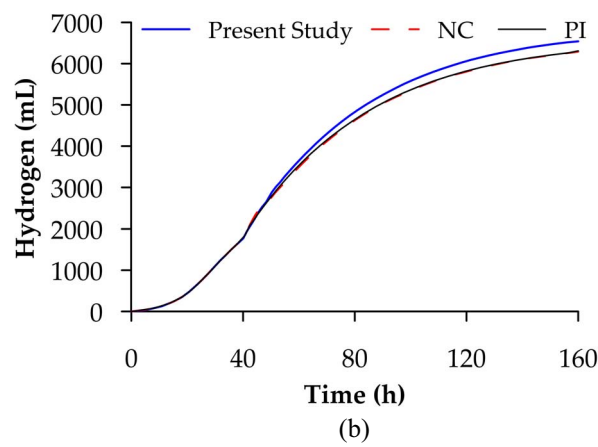
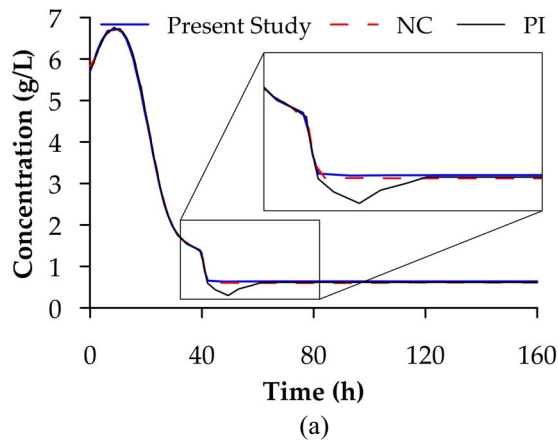

Figure 8. The amount of (a) substrate concentration and (b) hydrogen production in the closed-loop system by control system during the process.

increase from the open-loop condition in Figure 7b. The fuzzy control method outperforms other control methods, displaying its effectiveness in achieving higher hydrogen production levels. These results substantiate the impact of closed-loop control strategies on enhancing hydrogen production efficiency.

In Figure 9, when transitioning the control system to the closed-loop mode from the initial value of 40, all three controllers exhibit the capability to track the set value. Figure 8 depicts that the time multiplied by squared error (ITSE) performance index (Equation 10) associated with the NC controller consistently increases, indicating a persistent but small error within the controller. In contrast, the fuzzy controller displays superior performance, reflected in a lower ITSE performance index value. This superior efficacy in pursuing optimal set points contributes to an increase in hydrogen production, highlighting the advantages of the fuzzy controller in achieving precise control and minimizing errors.

$$\begin{aligned} \min_{k_p, k_I} \text{ITSE} &= \int_0^t te^2 dt \\ \text{s.t.} \quad &\begin{cases} k_p > 0 \\ k_I > 0 \end{cases} \end{aligned} \tag{10}$$

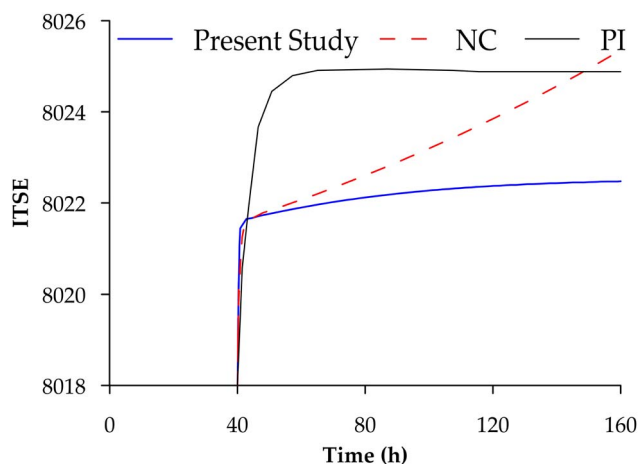

Figure 9. ITSE performance index variable for various control systems.

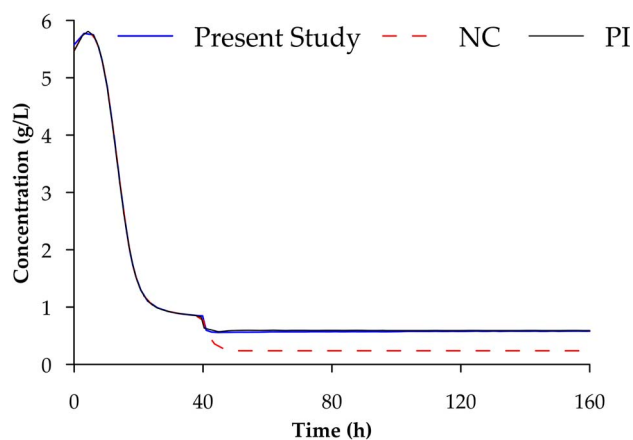

Figure 10. The amount of substrate concentration based on parametric model uncertainty.

3.4 Model uncertainty model on controller

This section explores the ramifications of model uncertainty on controller efficacy. Establishing a precise mathematical model that captures system behavior without any uncertainty proves to be a formidable and potentially unattainable task. This study recognizes two distinct categories of uncertainty, specifically parametric and structural. Parametric uncertainty, particularly concerning the parameters of the kinetic model, introduces complexity into the modeling process. Therefore, it becomes imperative to assess the performance of controllers while accounting for potential model uncertainties.

To address this challenge, all model parameters undergo a uniform modification of 33%, introducing a controlled level of uncertainty. Figure 10 visually presents the substrate concentration variations under parametric model uncertainty for three distinct controller systems. Of note, a NC, specifically designed to navigate the intricacies of complex and dynamic systems that defy accurate representation by linear models, is employed.

This shows how controllers respond when confronted with model uncertainties, emphasizing the adaptability and resilience

of non-linear control systems in handling intricate and dynamic scenarios. The findings contribute valuable insights into the robustness of controllers in real-world applications where uncertainties are inherent and need to be effectively managed.

4 CONCLUSIONS

This study provides a comprehensive discussion on managing substrate concentration in anaerobic hydrogen production reactors through the innovative application of the fuzzy logic method. Our numerical simulations reveal that effective process control has a notable positive impact on the quantity of hydrogen generated, resulting in the displacement of the system's equilibrium point from its initial position in the open-loop state to a predetermined value. This newly achieved equilibrium point signifies a pivotal juncture where the quantity of hydrogen generation surpasses that of its antecedent state.

Significantly, our findings underscore the superior performance of the fuzzy controller in augmenting biological hydrogen production compared to both the NC and the PI controller. The fuzzy controller demonstrates enhanced production performance by effectively addressing the inherent non-linear behavior and characteristics of the system. This contrasts with the observed lack of robustness in the NC when faced with system uncertainty. Notably, the fuzzy controller exhibits the ability to robustly track desired values even in the presence of model uncertainty.

Furthermore, our evaluation using the ITSE performance index reveals that the fuzzy controller outperforms the NC and PI controller, with a comparatively lower ITSE value. This indicates the effectiveness of the fuzzy method in regulating the hydrogen production process.

Our study demonstrates that the fuzzy method presents a viable approach to regulating the hydrogen production process, leading to a substantial increase of up to 95% in biological hydrogen production compared to the open-loop mode. This significant enhancement in production represents a crucial step toward the commercialization of hydrogen through this method. The application of such technologies in industrial settings not only holds promise for advancing environmentally friendly fuel production but also contributes to mitigating ecological harm, including the reduction of gases such as carbon dioxide and carbon monoxide emissions into the atmosphere.

AUTHOR CONTRIBUTIONS

Kairat A. Kuterbekov (Conceptualization [equal], Formal analysis [equal], Methodology [equal], Validation [equal]), Kenzhebatyr Zh. Bekmyrza (Conceptualization [equal], Investigation [equal], Methodology [equal], Resources [equal]), Asset M. Kabyshev (Conceptualization [equal], Data curation [equal], Methodology [equal], Writing—original draft [equal]), Marzhan M. Kubenova (Data curation [equal], Formal analysis [equal], Methodology [equal], Validation [equal], Writing—review & editing [equal]),

Mehrdad Shokatian-Beiragh (Investigation [equal], Software [equal], Visualization [equal], Writing—original draft [equal]).

ACKNOWLEDGEMENTS

The work was fulfilled in the frame of targeted financing program no. BR21882359, supported by the Ministry of Science and Higher Education of Kazakhstan.

REFERENCES

- [1] Davoodi A, Abbasi AR, Nejatian S. Multi-objective techno-economic generation expansion planning to increase the penetration of distributed generation resources based on demand response algorithms. *Int J Electr Power Energy Syst* 2022;**138**:107923.
- [2] Alaiwi Y, Taha A, AlJumaili Y. Enhancement of the polycrystalline solar panel performance using a heatsink cooling system with PCM. *Int J Eng Artif Intell* 2023;**4**:24–34.
- [3] Misbah Inayat S, Rafay Zaidi SM, Ahmed H. *et al.* Risk assessment and mitigation strategy of large-scale solar photovoltaic systems in Pakistan. *Int J Ind Eng Manag* 2023;**14**:105–21.
- [4] Taner T. The novel and innovative design with using H₂ fuel of PEM fuel cell: efficiency of thermodynamic analyze. *Fuel* 2021;**302**:121109.
- [5] Taner T. Energy and exergy analyze of PEM fuel cell: a case study of modeling and simulations. *Energy* 2018;**143**:284–94.
- [6] Beigzadeh M, Pourfayaz F, Ghazvini M. *et al.* Energy and exergy analyses of solid oxide fuel cell-gas turbine hybrid systems fed by different renewable biofuels: a comparative study. *J Clean Prod* 2021;**280**:124383.
- [7] Jalili M, Ghasempour R, Ahmadi MH. *et al.* Exergetic, exergo-economic, and exergo-environmental analyses of a trigeneration system driven by biomass and natural gas. *J Therm Anal Calorim* 2022;**147**:4303–23.
- [8] Jradi M, Riffat S. Medium temperature concentrators for solar thermal applications. *Int J Low-Carbon Technol* 2014;**9**:214–24.
- [9] A. Jasim M, K. Ahmed O, Alaiwi Y. Performance of solar stills integrated with PV/thermal solar collectors: a review. *NTU. J Renew Energy* 2023;**4**:97–111.
- [10] Yanto DTP, Akhmadeev R, Hamad HS. *et al.* Development and investigation of a pollutants emission reduction process from a coal-gasification power plant integrated with fuel cell and solar energy. *Int J Low-Carbon Technol* 2023;**18**:1120–33.
- [11] Farzaneh-Gord M, Mohseni-Ghareysafa B, Arabkoohsar A. *et al.* Precise prediction of biogas thermodynamic properties by using ANN algorithm. *Renew Energy* 2020;**147**:179–91.
- [12] Awogbemi O, Von Kallon DV. Recent advances in the application of nanomaterials for improved biodiesel, biogas, biohydrogen, and bioethanol production. *Fuel* 2024;**358**:130261.
- [13] Dutta N, Usman M, Ashraf MA. *et al.* Methods to convert lignocellulosic waste into biohydrogen, biogas, bioethanol, biodiesel and value-added chemicals: a review. *Environ Chem Lett* 2023;**21**:803–20.
- [14] Pareek A, Dom R, Gupta J. *et al.* Insights into renewable hydrogen energy: recent advances and prospects. *Mater Sci Energy Technol* 2020;**3**:319–27.
- [15] Patel SKS, Kumar P, Kalia VC. Enhancing biological hydrogen production through complementary microbial metabolisms. *Int J Hydrogen Energy* 2012;**37**:10590–603.
- [16] Samrot AV, Rajalakshmi D, Sathiyasree M. *et al.* A review on biohydrogen sources, production routes, and its application as a fuel cell. *Sustainability* 2023;**15**:12641.
- [17] Osman AI, Lai ZY, Farghali M. *et al.* Optimizing biomass pathways to bioenergy and biochar application in electricity generation, biodiesel production, and biohydrogen production. *Environ Chem Lett* 2023;**21**:2639–705.
- [18] Zhang X, Li H, Taghavi M. Exergoeconomic evaluation of a new carbon-free hydrogen and freshwater production system based on biomass gasification process. *Int J Low-Carbon Technol* 2023;**18**:589–99.
- [19] Foong SY, Chan YH, Cheah WY. *et al.* Progress in waste valorization using advanced pyrolysis techniques for hydrogen and gaseous fuel production. *Bioresour Technol* 2021;**320**:124299.
- [20] Aziz M, Darmawan A, Juangsa FB. Hydrogen production from biomasses and wastes: a technological review. *Int J Hydrogen Energy* 2021;**46**:33756–81.
- [21] Buffi M, Prussi M, Scarlat N. Energy and environmental assessment of hydrogen from biomass sources: challenges and perspectives. *Biomass Bioenergy* 2022;**165**:106556.
- [22] Vadivel S, Rajendran S, Mohan H. Surfactants, dispersants, enzymes, and microorganisms for oily wastewater treatment. In: *Oil? Water Mixtures and Emulsions, Volume 2: Advanced Materials for Separation and Treatment, 2022*, pp. 147–64. American Chemical Society.
- [23] Agyekum EB, Nutakor C, Agwa AM. *et al.* A critical review of renewable hydrogen production methods: factors affecting their scale-up and its role in future energy generation. *Membranes* 2022;**12**:173.
- [24] Zappi A, Hernandez R, Holmes WE. A review of hydrogen production from anaerobic digestion. *Int J Environ Sci Technol* 2021;**18**:4075–90.
- [25] Pfaffinger CE, Severin TS, Apel AC. *et al.* Light-dependent growth kinetics enable scale-up of well-mixed phototrophic bioprocesses in different types of photobioreactors. *J Biotechnol* 2019;**297**:41–8.
- [26] Kumar Gupta S, Kumari S, Reddy K. *et al.* Trends in biohydrogen production: major challenges and state-of-the-art developments. *Environ Technol* 2013;**34**:1653–70.
- [27] Ren N, Guo W, Wang X. *et al.* Effects of different pretreatment methods on fermentation types and dominant bacteria for hydrogen production. *Int J Hydrogen Energy* 2008;**33**:4318–24.
- [28] Kumar SVS, Kumar VR, Reddy GP. Nonlinear control of bioreactors with input multiplicities—an experimental work. *Bioprocess Biosyst Eng* 2005;**28**:45–53.
- [29] Ritonja J. Implementation of stir-speed adopted controllers onto a batch bioreactor for improved fermentation. *IEEE Access* 2021;**9**:16783–806.
- [30] Aceves-Lara C-A, Latrille E, Steyer J-P. Optimal control of hydrogen production in a continuous anaerobic fermentation bioreactor. *Int J Hydrogen Energy* 2010;**35**:10710–8.
- [31] Muthamilselvi P, Karunanithi T. Direct Digital Control of Bioreactor Systems. *Int J Chem Sci* 2010;**8**.
- [32] Rodríguez J, Ruiz G, Molina F. *et al.* A hydrogen-based variable-gain controller for anaerobic digestion processes. *Water Sci Technol* 2006;**54**:57–62.
- [33] López Pérez PA, Neria-González MI, Aguilar R. Increasing the biohydrogen production in a continuous bioreactor via nonlinear feedback controller. *Int J Hydrogen Energy* 2015;**40**:17224–30.
- [34] Lu C, Zhang H, Zhang Q. *et al.* An automated control system for pilot-scale biohydrogen production: design, operation and validation. *Int J Hydrogen Energy* 2020;**45**:3795–806.
- [35] Kamaraj M, Ramachandran KK, Aravind J. Biohydrogen production from waste materials: benefits and challenges. *Int J Environ Sci Technol* 2020;**17**:559–76.
- [36] Hassan NS, Jalil AA, Vo DVN. *et al.* An overview on the efficiency of biohydrogen production from cellulose. *Biomass Convers Biorefinery* 2020;**13**:8485–507.
- [37] Hitam CNC, Jalil AA. A review on biohydrogen production through photo-fermentation of lignocellulosic biomass. *Biomass Convers Biorefinery* 2020;**13**:8465–83.
- [38] Das SR, Basak N. Molecular biohydrogen production by dark and photo fermentation from wastes containing starch: recent advancement and future perspective. *Bioprocess Biosyst Eng* 2021;**44**:1–25.
- [39] Pandey P, Shinde VN, Deopurkar RL. *et al.* Recent advances in the use of different substrates in microbial fuel cells toward wastewater treatment and simultaneous energy recovery. *Appl Energy* 2016;**168**:706–23.
- [40] Lu C, Wang Y, Lee D-J. *et al.* Biohydrogen production in pilot-scale fermenter: effects of hydraulic retention time and substrate concentration. *J Clean Prod* 2019;**229**:751–60.

- [41] Obeid J, Magnin JP, Flaus JM. *et al.* Modelling of hydrogen production in batch cultures of the photosynthetic bacterium *Rhodobacter capsulatus*. *Int J Hydrogen Energy* 2009;**34**: 180–5.
- [42] Nuñez S, Garelli F, De Battista H. Sliding mode observer for biomass estimation in a biohydrogen production process. *Int J Hydrogen Energy* 2012;**37**:10089–94.
- [43] Nuñez S, Garelli F, De Battista H. Second-order sliding mode observer for biomass concentration and growth rate estimation in batch photo-bioreactors. *Int J Hydrogen Energy* 2014;**39**:8772–9.
- [44] García-Valdez M, Mancilla A, Castillo O. *et al.* Distributed and asynchronous population-based optimization applied to the optimal design of fuzzy controllers. *Symmetry* 2023;**15**:467.
- [45] Sim Y-B, Jung J-H, Baik J-H. *et al.* Dynamic membrane bioreactor for high rate continuous biohydrogen production from algal biomass. *Bioresour Technol* 2021;**340**:125562.